

Krakatoa™

Manufacture Cell Culture
Media at Point of Use While
Reducing Greenhouse Gas
Emissions by 65%



Krakatoa™ Benchtop Media Maker

Manufacture Cell Culture Media on Your Benchtop

Dispense cell culture media, buffers, and balanced salt solutions right from your benchtop with Krakatoa, the world's first benchtop media manufacturing system. Utilize compostable powder-filled pods and bring sustainability to your lab while you optimize and iterate your custom formulations.

Drive Optimized Performance

Iterate efficiently and identify optimized custom formulations in small volumes early in development. Plus, solubilization at point-of-use circumvents component degradation ensuring peak quality.

Scalable From Bench to Bioreactor

Formulations defined during early-stage iteration are stored in NB-Lux™ and can be scaled from pod to liquid in a bag or drum. Scale the production to match the demands of your commercialization efforts.

Lower Delivered Cost

Lightweight media pods lower shipping costs and nearly eliminate the need for refrigerated shipping. Custom media in smaller quantities for iteration decrease the upfront costs during testing phases.

Reduce Environmental Footprint

Krakatoa's lightweight biodegradable pods eliminate single-use PET bottles, decrease carbon emissions during shipping, and minimize the need for controlled temperature shipping.

Krakatoa at a Glance

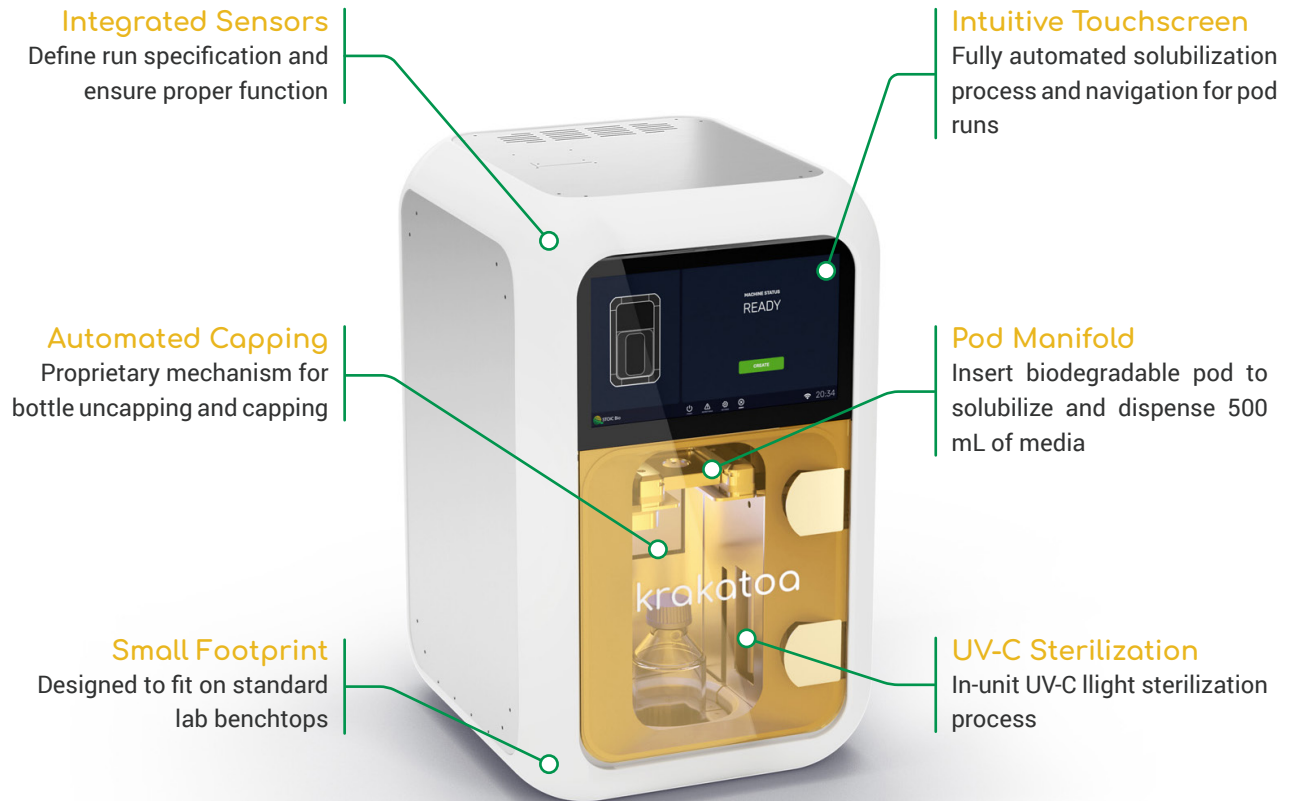

Make Your Cell Culture Science Sustainable

Reduced Environmental Impact

Krakatoa media maker significantly reduces the carbon footprint of your lab by reducing single-use plastics and the energy usage associated with your cell culture media. Through our independent in-depth life cycle analysis of the Krakatoa system, Krakatoa greenhouse gas (GHG) emissions represent a 65% reduction compared to conventional liquid media over the life cycle of a typical 500 mL volume of media.

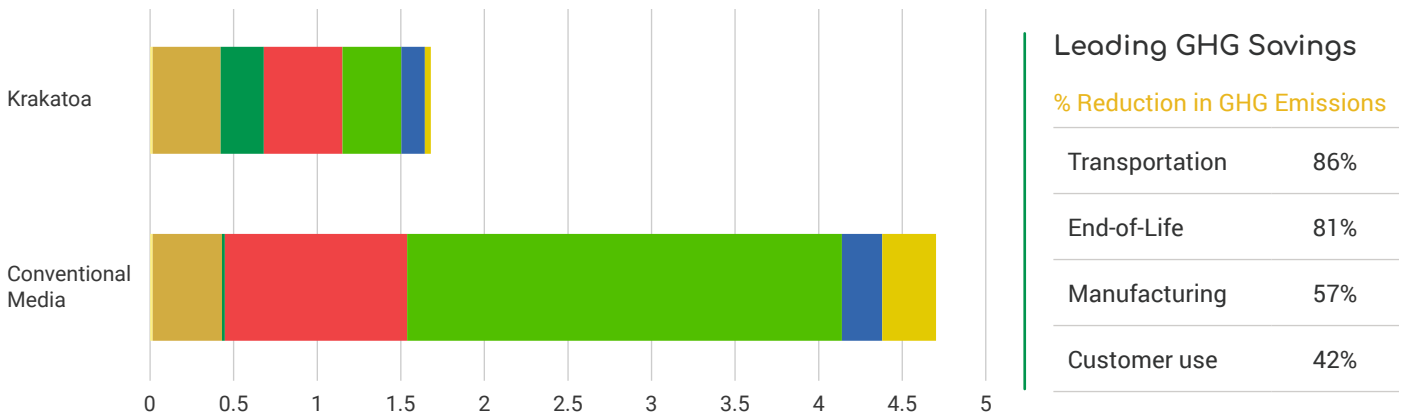

Save On Highly Customized Media

Because Krakatoa pods are lightweight and don't require refrigerated shipping and storage, in addition to the ability to manufacture at low volumes, Krakatoa can offer significant cost savings on highly customized media. Shipping the lighter podded media at ambient temperature is significantly less expensive than delivering liquid media and heavily impacts sustainability.

Sustainable Media - Quality Media

Amino Acid Profile

Consistency of your cell media product is critical to success of development. With Krakatoa, our protocols for pod filling and solubilization ensure media with equivalent quality and solubilized ingredient specifications as off-the-shelf media. In a direct comparison of Krakatoa mixed media and off-the-shelf media (DMEM/F-12 supplemented with 10% FBS), both media showed equivalent levels of amino acids when compared to a control specification.

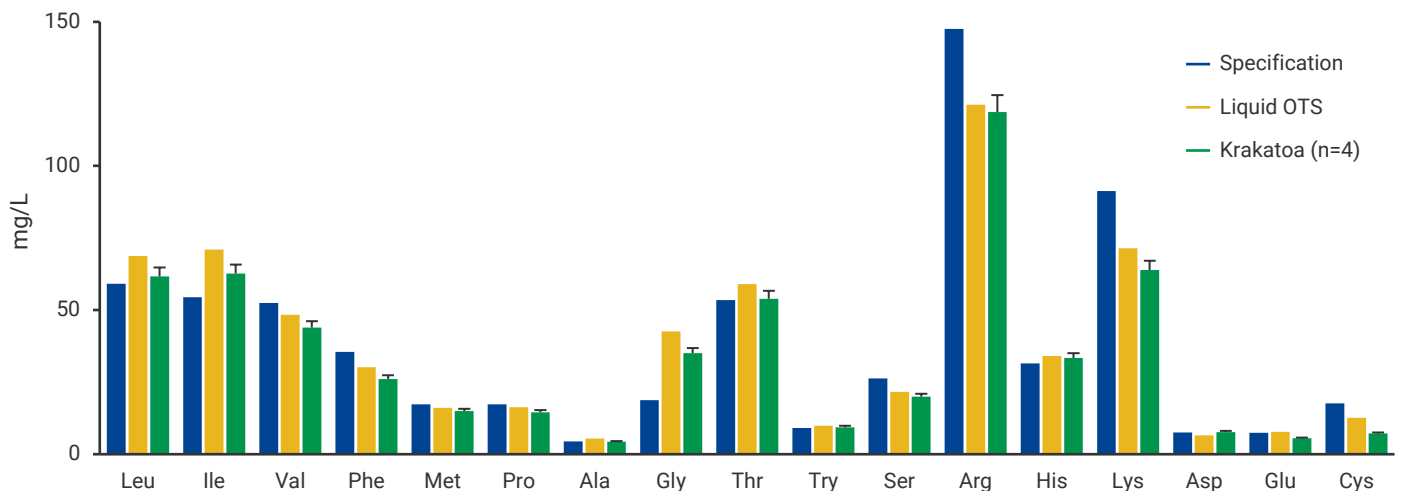

Cell Proliferation

Key amino acids and vitamins degrade following media solubilization due to light exposure⁽¹⁾ and storage temperatures^(2,3), amongst other factors affecting media potency. Other components, such as L-glutamine which breaks down into ammonia, may even have detrimental effects on cell growth and development efforts⁽²⁾. Solubilizing media at point-of-use with Krakatoa provides users with cell culture media containing guaranteed fresh components that have not been subjected to any degrading factors, producing media that is at peak freshness.

In comparing cell proliferation of DMEM/F-12 supplemented with 10% FBS using over-the-shelf media vs Krakatoa mixed media, our data shows equivalent cell confluence % from Day 0 as illustrated by the Incucyte® data (right) and the confluence of cells (left).

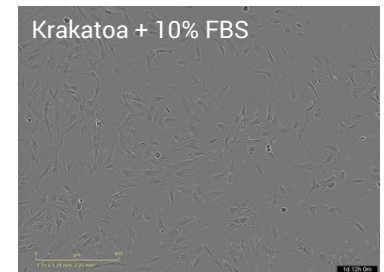
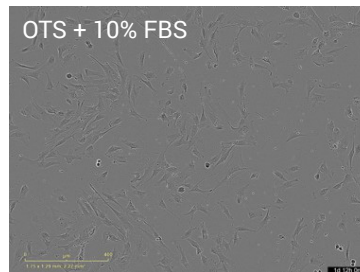
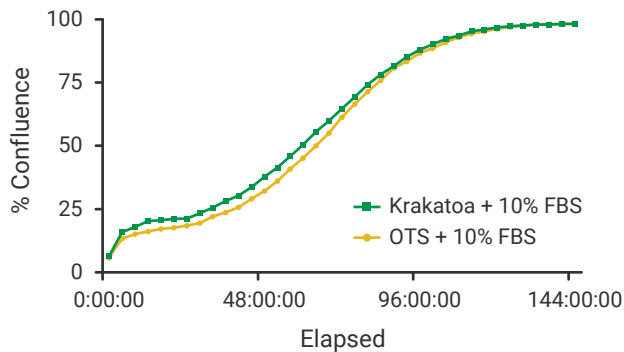

Designed With Convenience in Mind

Compact Design and Convenient Storage

Media pods require a fraction of the space necessary to store solubilized media and most do not require refrigeration. Also, Krakatoa's sleek benchtop design fits nicely in any lab.

Automated Media at the Touch of a Button

Intuitive user interface and automated workflows for calibration and cleaning provides a hands-free, point-of-use media manufacturing solution without any hassle.

Expedited Ordering and Production

Small-batch custom media pods delivered in 2 to 3 weeks. Krakatoa can manufacture multiple pods per hour.

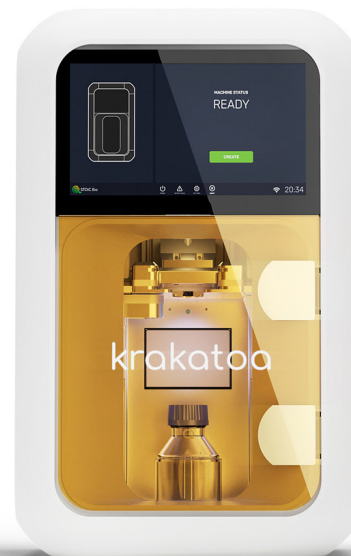

Synergistic Media Solutions

Krakatoa is designed to complement our portfolio of innovative products and services – from design to delivery.

- Create your custom media formulation using NB-AIR™ or have our formulation experts design one for you.
- Customize your formula, packaging, and testing and order your media on NB-Lux™.
- Solubilize your media sustainably at point of use with Krakatoa.

References

1. Hans Ingolf Nielsen, et al. (1991). Production of Biologicals from Animal Cells in Culture (pp. 82-84). Butterworth-Heinemann.
2. L. Tritsch, G.E. Moore. (1962). Exp. Cell Res. (pp. 360-364). Volume 28, Issue 2.
3. Amandine Calvet, Alan G. Ryder. (2014). Anal. Chimica Acta. (pp. 58-67). Volume 840.

Changing the Way Cell Culture Media Is Delivered

Fresh Media Manufactured on Your Benchtop!

Traditional liquid media is shipped in petroleum-based PET bottles that release GHG emissions when incinerated as biohazardous waste or take up to 400 years to decompose when dumped in landfills.

Krakatoa pods contain powdered media formulations and dispense 500 mL of fresh, ready-to-pipette custom and classical media, buffers, or balanced salts. The patented design of a Krakatoa pod features a self-contained capsule constructed from biodegradable shells capable of losing 90% of its mass in just one month.



Did You Know?

Krakatoa media pods are recyclable! Bring convenience and sustainability to your lab. Order, use, recycle – it's that simple.

Advanced Pod for Advanced Media

Pod Filterability

Krakatoa was evaluated for its capability in mixing media supplemented with large size proteins. In our study, we manufactured CMRL media, a complex media formulation supplemented with insulin and transferrin. CMRL was developed in collaboration with Dr. Elina Linetsky from the Diabetes Research Institute, University of Miami. CMRL was designed for enhanced in vitro functionality of human pancreatic islets. Media was tested for protein content after filtration and it showed comparable levels to the specification, proving that Krakatoa is capable of mixing, dispensing, and filtering advanced media.

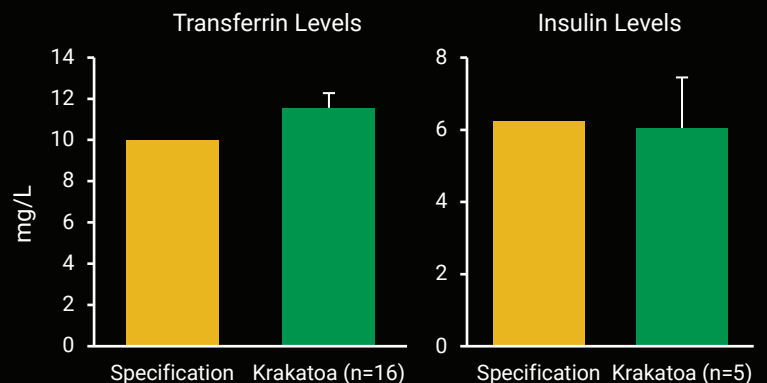

Product Specifications

Device Specifications

| | |
|---|--|
| Device Dimensions (W x H x D) | 17.1 x 27.6 x 19.1 (in) 434.45 x 700 x 485.3 (mm) |
| Suggested Footprint (W x D) | 25 x 31 (in) 635 x 787.4 (mm) |
| Weight | 120 lbs |
| Lighting | Philips 9W UV-C bulbs |

Pod Specifications

| | |
|--------------------------------------|---|
| Pod Dimensions (W x H x D) | 3.2 x 3 x 3.5 (in) 81 x 75.2 x 90 (mm) |
| Weight | 140 g |
| Source Material | Compostable and biodegradable bioplastic |
| Pod Filter | 0.2-micron pore size PES membrane |
| Solubilization Volume | 500 mL |
| Recyclable | Yes |

Starter Kit

- Footprint mat
- 3 x 500 mL empty Duran glass bottles
- 3 x buffer/balanced salt solution pods
- 3 x basal media pods
- Biodegradable bag holder
- Biodegradable recycling bags
- Pod evacuation tool

Krakatoa™ is a registered trademark of Stoic Bio, Inc. Nucleus Biologics LLC is an authorized distributor for Stoic Bio, Inc. of Krakatoa and its related products. Stoic Bio, Inc. is a spinoff of Nucleus Biologics, LLC with similar ownership and was created to develop and commercialize Krakatoa and its related products.

Stoic Bio
10929 Technology Place | San Diego, CA 92127
844.400.3118 | info@stoicbio.com | www.stoicbio.com
©2023. Stoic Bio. All rights reserved.

Device Specifications (Continued)

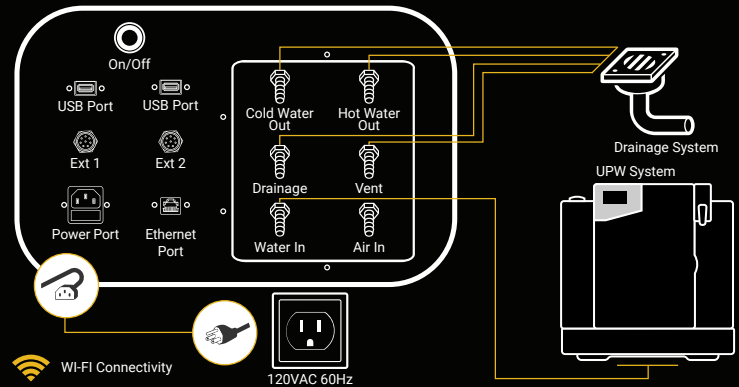

| | |
|-------------------------------------|---|
| Internet | Wi-Fi connectivity; requires minimum of -57 dB signal strength or ethernet connection |
| Plug-ins | Refer to schematic. USB port is only to be used by the field service engineer for validation and troubleshooting purposes. |
| Energy Consumption (Wattage) | <p>Standby Mode: 30W</p> <p>Standby mode can be reduced by optimizing power saving features such as disabling lighting and idle motor currents when the machine is not in use.</p> <p>Active Mode:</p> <p>Heating system disengaged: 160W (30 mins per pod)</p> <p>Heating system engaged: 1550 W (approx. 10 mins per pod)</p> |
| Power Source | <p>Outlet: Type B socket power outlet (120VAC 60 Hz). Power cord can be plugged directly into the outlet; no voltage converters or other materials necessary.</p> <p>Supplied Materials: NEMA 5-15 type B plug, IEC C13 plug cable; appropriate cables will be provided based on region</p> |
| Water System Hook-Up | <p>Recommended System: Ultrapure water (UPW) system or lab water system</p> <p>Minimum System Requirements: Type II water or better, according to American Society for Testing and Materials (ASTM)</p> <p>Supplied Materials: Silicone tubing; pneumatic tube cutter</p> |
| Drainage | <p>System Requirements: Drainage system; if standard system is unavailable, provision for 1L of drainage</p> <p>Supplied Materials: Silicone tubes; pneumatic tube cutter</p> <p>Length of provided tubes is 3 ft; users may determine where to place the instrument relative to the drainage area within this length.</p> |